

## Revision History

Rev	Description	Date	Approved
A	Initial Release	07/01/24	JB

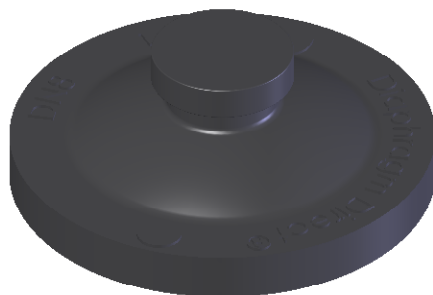

**Replacement Diaphragm for:-**  
**OEM PART = 50059**  
**USED ON DN8 Diaphragm Valve**

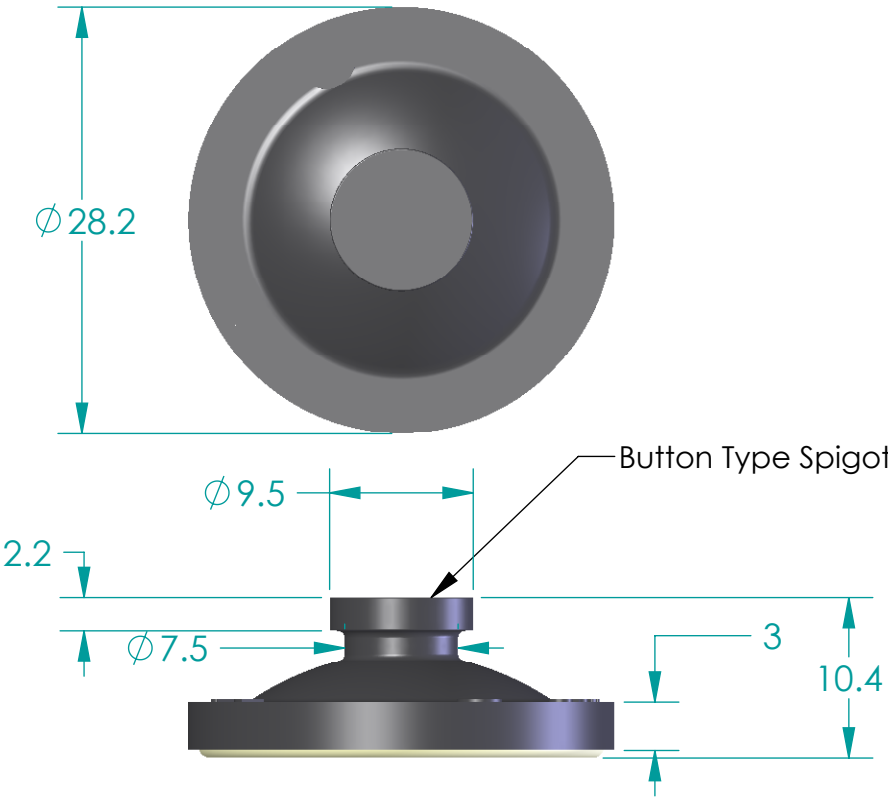
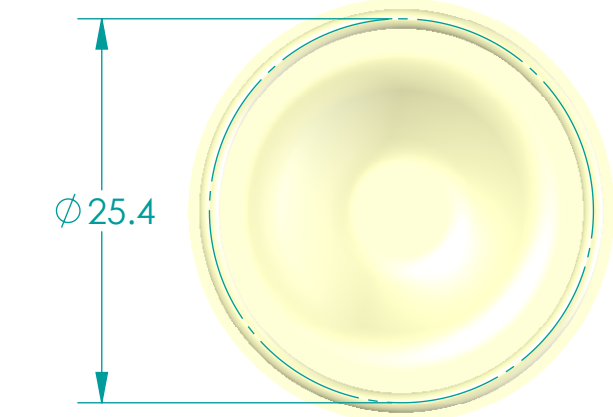

Disclaimer - Diaphragm Direct® does not manufacture, represent, nor sell OEM valves or diaphragms manufactured by any other company. Diaphragm Direct® brand diaphragms are not sponsored by any other manufacturers. Any name, model, part number, brand, image, material or referral is for descriptive purposes only. Diaphragm Direct® brand replacement diaphragms are guaranteed to fit OEM equipment and meet or exceed OEM specifications. Diaphragm Direct® brand replacement diaphragms are covered by the standard Diaphragm Direct® limited product warranty.

	Name	Date	<b>DIAPHRAGM<sup>®</sup> DIRECT</b>	
Drawn	M.Mc Keon	30/06/24		
Checked				
<b><u>Material -</u></b> <b><u>EPDM-BACKING</u></b> <b><u>TFM - DIAPHRAGM</u></b>			TITLE <b>DD03-BATFML</b>	
Complies with CFR 177.2600 and Conforms to USP Class VI Biological Reactivity Tests Section #87 and #88			Size A	FOOT PRINT DIMENSIONS
File Name: <b>DD03-BATFML</b>			Rev A	
SCALE: 1:1			Sheet 1 of 1	